

174.01.02
Excerpt from the
Leybold Vacuum Full Line Catalog 2005
Product Section C11
Edition May 2005

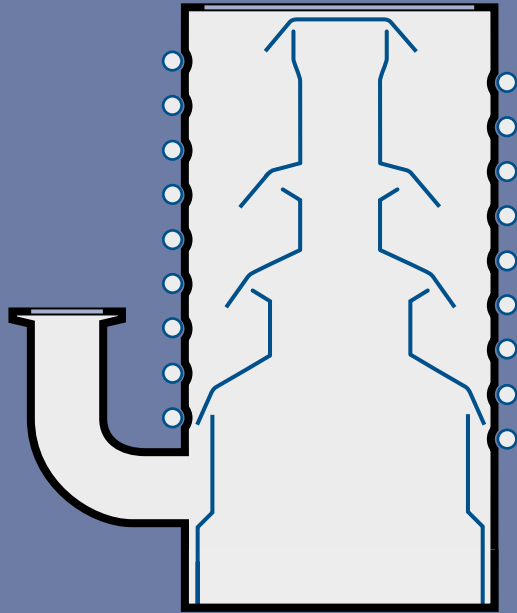

C11

DIP

Oil Diffusion Pumps
3000 - 50000 l x s⁻¹
Oils, Baffles, Accessories,
Adsorption Traps

General

Operating Principle of Fluid Entrainment Vacuum Pumps	C11.03
Applications and Accessories	C11.03
General, Diffusion Pumps	C11.04
Attainable Ultimate Pressures with Oil Diffusion Pumps	C11.05
Pump Fluids for Diffusion Pumps	C11.06
Overview Pump Fluids	C11.07

Products

DIP Pumps, Water-Cooled	C11.08
-----------------------------------	---------------

Accessories

Astrotorus Baffles	C11.12
Monitoring Instruments	C11.14
Adsorption Traps with Aluminium Oxide Insert	C11.16

Operating Principle of Fluid Entrainment Vacuum Pumps

The main components of diffusion pumps, the operation of which relies on vapor-phase pump fluids are:

- Cooled pump body with intake and exhaust ports
- System of nozzles
- Pump boiler

In the case of diffusion pumps a pump fluid contained in a boiler is heated to such an extent that it is vaporized. The vapor is then forced through nozzles within the pump. The nozzles are generally designed in such a way, that they accelerate the vapor to a speed exceeding the speed of sound (Laval nozzles), thus creating a high speed vapor jet. The vapor is then deflected by the nozzles at a specific angle onto the

pump body. The pump body is cooled, so that the vaporized pump fluid condenses and is returned back to the boiler as a liquid. The pumping action of diffusion pumps and fluid entrainment pumps in general is based on the transporting capacity of the vapor jet.

The gas which is to be pumped is compressed sufficiently at the fore-vacuum port so that it can be pumped out by a backing pump.

Applications and Accessories

Pumps		DIP 3 000	DIP 8 000	DIP 12 000	DIP 20 000	DIP 30 000	DIP 50 000
Application							
Vacuumcoating		■	■	■	■	■	■
Research and development		■	■	■	■	■	■
Metallurgy/furnaces		■	■	■	■	■	■
Mechanical engineering		■	■	■	■	■	■
Accessories							
	Page						
Pump fluids	C11.06	■	■	■	■	■	■
Astrotorus baffle	C11.12	■	■	■	■	■	■
Water flow monitor	C11.14	■	■	■	■	■	■
Over-temperature protection switch	C11.15	■	■	■	■	■	■
Contact thermometer	C11.15	■	■	■	■	■	■
Resistance thermometer Pt 100	C11.15	■	■	■	■	■	■
Adsorption trap	C11.16	For generating an oil-free vacuum with oil-sealed backing pumps					

General

Diffusion Pumps

Compared to other fluid entrainment pumps the density of the vapor in the boiler and in the vapor jet is fairly low so that the gas molecules may almost completely diffuse into the vapor jet. Thus most of the molecules which enter the vapor jet are also pumped out.

For this reason, the pumping speed of diffusion pumps is extremely high with respect to the in-take area and constant – starting at an inlet pressure of approximately 10^{-3} mbar (0.75×10^{-3} Torr) down to very low pressures – as within the pressure range the vapor jet is not influenced in any way by the pressure within the vacuum vessel.

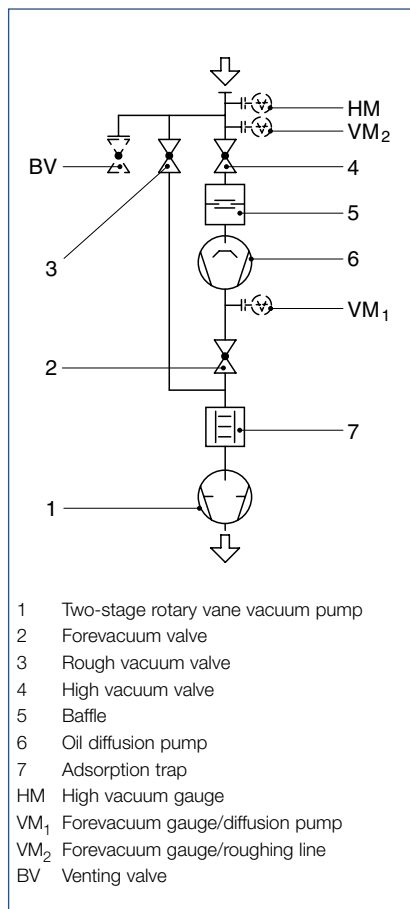

Diagram of a pump system with diffusion pump

Operating Oil Diffusion Pumps

Forevacuum

In all cases diffusion pumps require a sufficiently sized backing pump (see Technical Data). The size and type of forevacuum pump depends on the operating conditions and the quantities of gas which are to be pumped.

1. Continuous operation at operating pressures above 10^{-4} mbar (0.75×10^{-4} Torr) – large quantities of gas.
2. Continuous operation at operating pressures below 10^{-4} mbar (0.75×10^{-4} Torr) – smaller quantities of gas.

In applications which rely on diffusion pumps, the vacuum chamber must be connected via a valve (3) and a roughing line directly to the backing pump. This is done so that the vacuum chamber may be pre-evacuated by the backing pump down to a pressure where the diffusion pump can take over. Until the high vacuum valve (4) opens, both diffusion pump and pump fluid are preserved. Before venting the vacuum chamber the forevacuum valve (2) and the high vacuum valve (4) must be closed, whereby the diffusion pump remains in the ready status.

Pumping Speed

The pumping speed of any pump is equivalent to the volume throughput through the intake opening of a pump. In the case of diffusion pumps the pumping speed for lighter gases is higher compared to heavier gases.

Backstreaming of the Pump Fluid

Undesirable backstreaming of molecules from the pump fluid is caused by the effect that some molecules are able to leave the vapor jet and thus do not arrive at the cooled pump body. Because of collisions between each other and due to reflection at the pump body, these molecules are then able to move in the direction of the vacuum chamber.

For DIP pumps the backstreaming effect amounts only to a few μg per cm^2 of intake area per minute. Backstreaming may be almost completely suppressed by including a cold cap baffle or an additional Astrotorus baffle.

Backstreaming of Oil in the Case of Diffusion Pumps

- Pump without baffle
approx. 1×10^{-2} mg \times cm^{-2} \times min^{-1}
- Pump with cold cap baffle
approx. 1×10^{-3} mg \times cm^{-2} \times min^{-1}
- Pump with Astrotorus baffle
($T = 10^\circ\text{C}$ (50°F))
approx. 1×10^{-5} mg \times cm^{-2} \times min^{-1}

The values stated were measured at the ultimate pressure and apply to DIFFELEN normal. When using DC 705 the values may improve on average by one order of magnitude.

Attainable Ultimate Pressure

The attainable ultimate pressure for a particular vacuum system depends not only on the type and pumping speed rating of the diffusion pump, but also on the vapor pressure of the pump fluid, shape and temperature of the baffle, leaks at connecting flanges or welded joints and the condition of the surfaces within the vacuum chamber. When excluding all effects which contribute to an increase in pressure within the

vacuum chamber due to leaks and contamination of the vacuum chamber walls, it will be possible to attain the ultimate pressures stated in the table "Attainable Ultimate Pressures with Oil Diffusion Pumps (DIP)" given in section "General".

In practice the following combination has been found to work very well when needing a low vacuum free of oil vapors.

- Water-cooled cold cap baffle as a integral part of the diffusion pump together with a water-cooled Astrotorus baffle which may be installed as an additional component on the high vacuum flange of the diffusion pump.

Sealing Methods

For ultimate pressures down to 10^{-8} mbar (0.75×10^{-8} Torr) bakeout temperatures of up to 150 °C (302 °F) are sufficient. FPM (FPM = Fluor caoutchouc, temperature resistant up to 150 °C (302 °F)) sealing rings or ultra sealing rings made of aluminum must be used.

In order to prevent pressure variations, ultra sealing rings must be used in the connections, between diffusion pump and baffle.

Ultimate pressures below 10^{-8} mbar (0.75×10^{-8} Torr) require bakeout temperatures up to 400 °C (752 °F). However, it is only necessary to bake out the vacuum chamber to 400 °C (752 °F) and to maintain a temperature gradient across the baffle or the cold trap so that a temperature of 150 °C (302 °F) is not exceeded at the intake flange of the pump.

In this way, it is still acceptable to use FPM sealing rings or ultra sealing rings made of aluminium.

Cooling

The cooling water temperature should not exceed 25 °C (77 °F) at the intake and 30 °C (86 °F) at the discharge, otherwise sufficient condensation of the pump fluid cannot be ensured. When connecting the cooling system of the pump and the baffle in series, the cooling water must always be made to flow through the baffle first and then through the diffusion pump, because the attainable ultimate pressure in the vacuum chamber depends strongly on the condensation temperature of the pump fluid in the baffle.

Attainable Ultimate Pressures with Oil Diffusion Pumps DIP

Attainable Ultimate Pressure ¹⁾		DIFFELEN normal (or DC 704)	DIFFELEN ultra	DC 705	Polyphenylether ULTRALEN
Without baffle	mbar (Torr)	1.5×10^{-6} (1.1×10^{-6})	6×10^{-7} (4.5×10^{-7})	4.0×10^{-7} (3.0×10^{-7})	4.0×10^{-7} (3.0×10^{-7})
With cold cap baffle	mbar (Torr)	5×10^{-7} (3.8×10^{-7})	3.0×10^{-7} (2.3×10^{-7})	1.5×10^{-7} (1.1×10^{-7})	1.0×10^{-7} (0.75×10^{-7})
With Astrotorus baffle	mbar (Torr)	1.5×10^{-7} (1.1×10^{-7})	3.0×10^{-8} (2.3×10^{-8})	1.5×10^{-8} (1.1×10^{-8})	1.5×10^{-8} (1.1×10^{-8})

¹⁾ Attained in consideration of the notes given under "Sealing Methods" in the section "General" and after degassing the connected vacuum chamber for several hours at 200 °C (392 °F)

Pump Fluids for Diffusion Pumps

Pump fluids for oil diffusion pumps must exhibit a low vapor pressure at room temperature and must be able to resist thermal decomposition and oxidization to a large extent. Surface tension of the pump fluids must be high to reduce creep of oil films. They must be chemically inert, exhibit high flash point and evaporation heat must be low. Moreover, the pump fluids should permit high pumping speeds over a wide range of pressures and be cost-effective.

One type of pump fluid alone cannot meet these comprehensive requirements. It is therefore required to select a pump fluid according to the operating pressure and the requirements of the application in each case.

The pump fluids given below are subjected to an extensive series of tests in our factory laboratories under conditions commonly encountered in practice by diffusion pumps.

We recommend the use of the pump fluids specifically qualified by Leybold, since only this will ensure that the specifications will be met by our diffusion pumps in practice. Equally we recommend the use of qualified pump fluids to attain the optimum oil change intervals and prevent the accumulation of unwanted deposits.

Material safety data sheets are available upon request for professional users from:
Email „safety-data@leyboldvac.de“ or from the Internet „www.leybold.com/safety-data“.

Mineral Oil Pump Fluid DIFFELEN

The various types of this kind of pump fluid are closely tolerated fractions of a high quality base product distilled with particular care. During the distillation process the pressure and temperature conditions are maintained continuously within close limits, so that individual fractions are obtained which are of consistent quality.

- **DIFFELEN normal** is the most frequently used pump fluid. It is the ideal pump fluid for high vacuum applications. The attainable ultimate pressure is below 10^{-7} mbar (0.75×10^{-7} Torr).
- **DIFFELEN ultra** is used in connection with ultrahigh vacuum pump systems. With a water-cooled baffle the attainable ultimate pressure is about 10^{-8} mbar (0.75×10^{-8} Torr).

Polyphenylether

ULTRALEN is a high-quality pump fluid based on a polyphenylether for operation in the high vacuum range. It excels through its very high resistance against oxidation, thermal decomposition and chemical attack, and exhibits an exceptionally low vapour pressure.

Silicone Oil

Silicone oil differs from DIFFELEN oil in that silicone oil is a defined chemical compound which is extremely resistant to decomposition. Because of the extremely low vapor pressure, silicone oil is especially well suited as a pump fluid in diffusion pumps. Even after a great number of air inrushes, silicone oil will remain unaffected by aging even when subjected to mass spectrometric analysis.

DC 704 is a pump fluid for high vacuum and ultra high vacuum applications with stringent requirements concerning resistance against oxidization and decomposition.

DC 705 is a special pump fluid (an organic silicon compound) for ultrahigh vacuum applications which require an extremely low vapor pressure together with stringent requirements concerning resistance against oxidization and decomposition.

Overview Pump Fluids

Technical Data	Mineral Oil/DIFFELEN	
	normal	ultra
Vapor pressure at 20 °C (68 °F) mbar (Torr)	4×10^{-9} (3×10^{-9})	4×10^{-11} (3×10^{-11})
Middle molecular weight g/mol	510	600
Flash point °C (°F)	> 258 (> 496)	> 270 (> 518)
Dyn. viscosity at 25 °C (77 °F) mPas	200	220
Kin. viscosity at 40 °C (104 °F) mm ² /s	100	110
Density at 20 °C (68 °F) g/ml	0.87	0.87
Ordering Information	Mineral Oil/DIFFELEN	
	normal	ultra
0.5 l (0.47 qts)	Part No. 176 73	Part No. 176 71
5.0 l (4.7 qts)	Part No. 176 72	–

Technical Data	Silicone Oil		Polyphenylether ULTRALEN
	DC 704	DC 705	
Vapor pressure at 20 °C (68 °F) mbar (Torr)	3×10^{-8} (2.8×10^{-8})	4×10^{-10} (3×10^{-10})	3×10^{-10} (2.3×10^{-10})
Middle molecular weight g/mol	485	545	450
Flash point °C (°F)	221 (430)	243 (469)	288 (611)
Dyn. viscosity at 25 °C (77 °F) mPas	47	190	2900
Kin. viscosity at 40 °C (104 °F) mm ² /s	24	66	370
Density at 20 °C (68 °F) g/ml	1.07 ¹⁾	1.09 ¹⁾	1.20
Ordering Information	Silicone Oil		Polyphenylether ULTRALEN
	DC 704	DC 705	
0.05 l (0.047 qts)	–	–	Part No. 155 72
0.5 l (0.47 qts)	Part No. 176 94	Part No. 176 96	–
5.0 l (4.7 qts)	Part No. 500 600 ²⁾	–	–
1.0 gal (DC 704 CA)	Part No. 981 98 069	–	–
5.0 gal (DC 704 CP)	Part No. 981 98 070	–	–

¹⁾ At 25 °C (77 °F)

²⁾ 5 kg (11.4 lbs)

Please note that the technical data stated are only typical data. Slight variations from batch to batch must be expected. The technical data given here can not be taken as assured data

DIP Pumps, Water-Cooled



DIP 12.000

The DIP range of pumps was developed for operation in industrial systems. Excellent vacuum performance data combined with the inherent ruggedness of this kind of pump, make our diffusion pumps a reliable component in high and medium vacuum applications.

Advantages to the User

- High pumping speeds in the fine and high vacuum ranges
- Low attainable ultimate pressure
- Integrated, water-cooled cold cap baffle guarantees low oil back-streaming rates into the vacuum chamber
- Low oil losses (even at high gas throughputs) by integrated water-cooled forevacuum baffle
- High forevacuum resistance even at reduced heating power
- The heating cartridges are accessible from the outside via heating inserts which are built into the boiler. This ensures a quick exchange of single heating cartridges (even when the pump is hot)
- A separate automatic circuit breaker for each heating cartridge ensures a high level of electrical safety
- A standard built-in thermostat acts as an thermal overload switch and ensures that the heating cartridges can not overheat
- All pumps are prepared for installation with an over-temperature switch (optional) for checking the cooling water circuit, and a contact thermometer (optional) to monitor the operating temperature of the diffusion pump
- Indication of the oil level by sight-glass permits simple checking of the current oil level
- All DIP pumps are delivered with their inside chamber cleaned in such a manner that it is free of oil. The inside is evacuated. In the condition as delivered, the pumps may be also operated with silicone oil

Typical Applications

The diffusion pumps from the DIP range are used in coating systems, vacuum melting and drying systems as well as in vacuum furnaces in the area of metallurgy.

Supplied Equipment

The DIP pumps are supplied ready for connection but without the filling of pump fluid.

The inside of the pump is cleaned before delivery to such an extent that it is free of oil. The inside is evacuated. High and forevacuum flanges are equipped with gaskets and centering rings having shipping flanges and complete with clamping components.

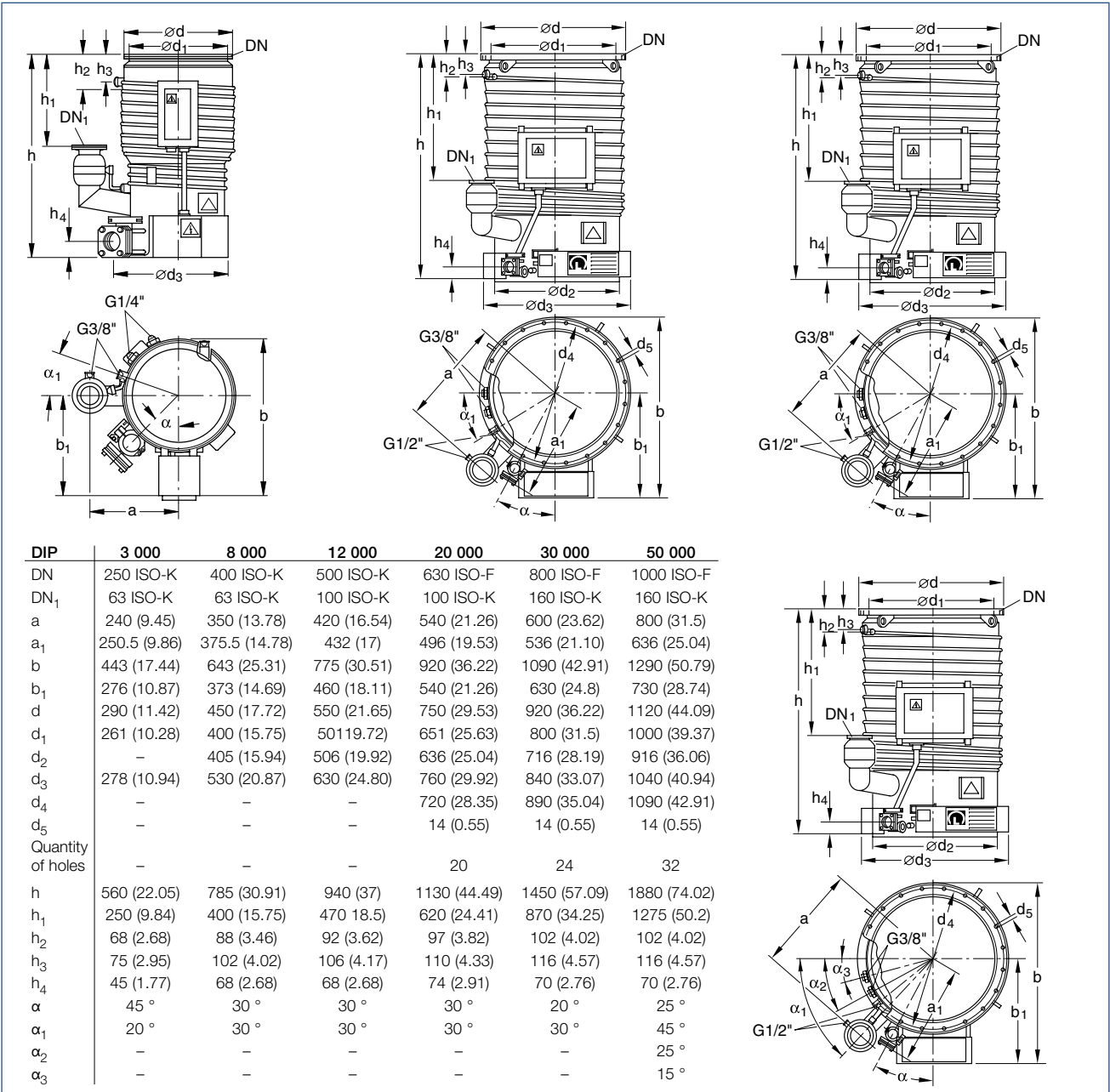

Dimensional drawing for the DIP 3000 [top left], DIP 8000 to DIP 20 000 [top middle], DIP 30 000 [top right] and DIP 50 000 [bottom right]; Dimensions in brackets () are in inch

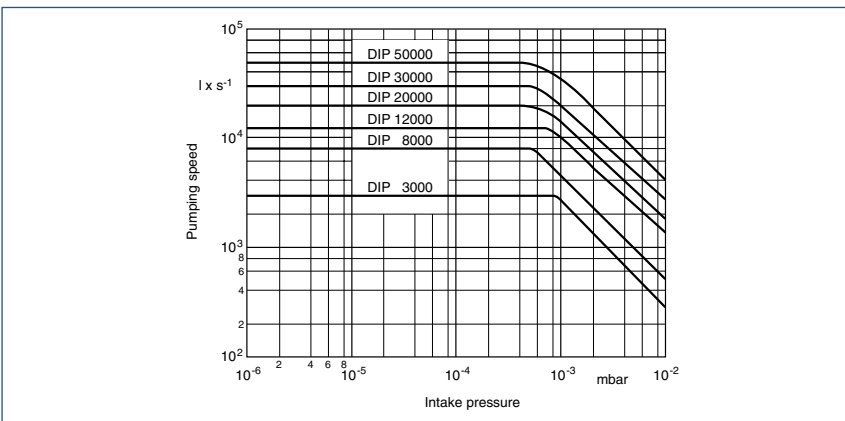

Pumping speed characteristics of the DIP pumps as a function of intake pressure

Technical Data	DIP 3 000	DIP 8 000	DIP 12 000
High vacuum/forevacuum connection DN	250 ISO-K/63 ISO-K	400 ISO-K/63 ISO-K	500 ISO-K/100 ISO-K
Pumping speed for air ¹⁾ below 1 x 10 ⁻⁴ mbar l x s ⁻¹	3 000	8 000	12 000
Operating range mbar (Torr)	< 10 ⁻² to 10 ⁻⁷ (0.75 x 10 ⁻² to 0.75 x 10 ⁻⁷)	< 10 ⁻² to 10 ⁻⁷ (0.75 x 10 ⁻² to 0.75 x 10 ⁻⁷)	< 10 ⁻² to 10 ⁻⁷ (0.75 x 10 ⁻² to 0.75 x 10 ⁻⁷)
Ultimate total pressure ²⁾ mbar (Torr)	< 5 x 10 ⁻⁷ (6.7 x 10 ⁻⁷)	< 5 x 10 ⁻⁷ (6.7 x 10 ⁻⁷)	< 5 x 10 ⁻⁷ (6.7 x 10 ⁻⁷)
Max. permissible forevacuum pressure mbar (Torr)	6 x 10 ⁻¹ (4.5 x 10 ⁻¹)	6 x 10 ⁻¹ (4.5 x 10 ⁻¹)	6 x 10 ⁻¹ (4.5 x 10 ⁻¹)
Pump fluid filling, min. / max. l (qts)	1.0 / 1.4 (1.1 / 1.5)	1.7 / 3.4 (1.8 / 3.6)	2.4 / 5.3 (2.5 / 5.6)
Mains connection			
Standard EURO, 50/60 Hz Standard Americas, 50/60 Hz Special, 50/60 Hz	V V V	230 ~ 1 Ph 230 ~ 1 Ph –	400 ~ 3 Ph Y 460 ~ 3 Ph Y 230 ~ 3 Ph Δ
Heating power kW	2.4	4.8	7.2
Number of heating cartridges	2	6	9
Heating up time min	< 25	< 25	< 25
Cooling water (minimum) for pump ³⁾ for cold cap baffle Max. supply pressure	l x h ⁻¹ (gal/min) l x h ⁻¹ (gal/min) bar (psig)	160 (0.7) 20 (0.09) 6 (87)	290 (1.28) 30 (0.13) 6 (87)
Number of cooling circuits (including cold cap baffle)	2	2	2
Cooling water connection for pump for cold cap baffle	G (BPS) G (BPS)	3/8" 1/4"	1/2" 3/8"
Weight, approx. kg (lbs)	29 (64)	70 (154)	102 (225)
Recommended backing pump ⁴⁾ at operating pressures > 10 ⁻⁴ mbar (> 0.75 x 10 ⁻⁴ Torr) at operating pressures < 10 ⁻⁴ mbar (< 0.75 x 10 ⁻⁴ Torr)	TRIVAC D 65 B + W 251 TRIVAC D 25 B	DK 200 + W 251 TRIVAC D 65 B + W 251	DK 200 + W 501 TRIVAC D 65 B + W 251
Ordering Information	DIP 3 000	DIP 8 000	DIP 12 000
Oil diffusion pump Standard EURO Standard Americas Special	Part No. 222 10 Part No. 222 10 –	Part No. 222 20 Part No. 500 670 Part No. 500 649	Part No. 222 25 Part No. 500 591 Part No. 500 651
Astrotorus baffle	Part No. 227 50	Part No. 227 60	Part No. 227 65
Water flow monitor LR 10 LR 20	Part No. 122 82 –	Part No. 122 82 –	– Part No. 122 83
Over-temperature protection switch	Part No. 122 84	Part No. 122 84	Part No. 122 84
Contact thermometer	Part No. 218 81	Part No. 218 81	Part No. 218 81
Resistance thermometer Pt 100 sensor	Part No. 200 02 958	Part No. 200 02 958	Part No. 200 02 958
Pump fluid ⁵⁾	see "Pump Fluids for Diffusion Pumps" in section "General"		

¹⁾ Measured to DIN 28 427 with **DIFFELEN normal** as the pump fluid

²⁾ Measured to DIN 28 427 with **DIFFELEN normal** as the pump fluid. With pump fluids DC 705 and FPM gaskets the DIP pumps - when equipped with water-cooled baffles and after running a suitable degassing processes - are capable of attaining pressures below 1 x 10⁻⁸ mbar (0.75 x 10⁻⁸ Torr)

³⁾ The required quantity of cooling water refers to DT = 10 °C (50 °F). The discharge temperature should not exceed 30 °C (86 °F)

⁴⁾ Single- or two-stage rotary vane (TRIVAC; SV) or rotary piston vacuum pumps (E/DK) from our range of forevacuum pumps jointly with Roots vacuum pumps (RUVAC) in pump systems

⁵⁾ Oil must be purchased separately

Technical Data	DIP 20 000	DIP 30 000	DIP 50 000	
High vacuum/forevacuum connection DN	630 ISO-F/100 ISO-K	800 ISO-F/160 ISO-K	1000 ISO-F/160 ISO-K	
Pumping speed for air ¹⁾ below 1 x 10 ⁻⁴ mbar l x s ⁻¹	20 000	30 000	50 000	
Operating range mbar (Torr)	< 10 ⁻² to 10 ⁻⁷ (0.75 x 10 ⁻² to 0.75 x 10 ⁻⁷)	< 10 ⁻² to 10 ⁻⁷ (0.75 x 10 ⁻² to 0.75 x 10 ⁻⁷)	< 10 ⁻² to 10 ⁻⁷ (0.75 x 10 ⁻² to 0.75 x 10 ⁻⁷)	
Ultimate total pressure ²⁾ mbar (Torr)	< 5 x 10 ⁻⁷ (6.7 x 10 ⁻⁷)	< 5 x 10 ⁻⁷ (6.7 x 10 ⁻⁷)	< 5 x 10 ⁻⁷ (6.7 x 10 ⁻⁷)	
Max. permissible forevacuum pressure mbar (Torr)	6 x 10 ⁻¹ (4.5 x 10 ⁻¹)	6 x 10 ⁻¹ (4.5 x 10 ⁻¹)	6 x 10 ⁻¹ (4.5 x 10 ⁻¹)	
Pump fluid filling, min. / max. l (qts)	5.0 / 9.0 (5.3 / 9.5)	7.0 / 15.0 (7.4 / 15.9)	12.0 / 25.0 (12.7 / 26.4)	
Mains connection				
Standard EURO, 50/60 Hz V	400 ~ 3 Ph Y	400 ~ 3 Ph Y	400 ~ 3 Ph Y	
Standard Americas, 50/60 Hz V	460 ~ 3 Ph Y	460 ~ 3 Ph Y	460 ~ 3 Ph Y	
Special, 50/60 Hz V	230 ~ 3 Ph Δ	230 ~ 3 Ph Δ	230 ~ 3 Ph Δ	
Heating power kW	12	18	24	
Number of heating cartridges	12	18	24	
Heating up time min	< 25	< 30	< 30	
Cooling water (minimum) for pump ³⁾ for cold cap baffle Max. supply pressure	l x h ⁻¹ (gal/min) l x h ⁻¹ (gal/min) bar (psig)	600 (2.6) 60 (0.26) 6 (87)	900 (4.0) 80 (0.35) 6 (87)	1500 (6.6) 150 (0.66) 6 (87)
Number of cooling circuits (including cold cap baffle)	2	3	3	
Cooling water connection for pump for cold cap baffle	G (BPS) G (BPS)	1/2" 3/8"	1/2" 3/8"	
Weight, approx. kg (lbs)	172 (379)	296 (653)	560 (1235)	
Recommended backing pump ⁴⁾ at operating pressures > 10 ⁻⁴ mbar (> 0.75 x 10 ⁻⁴ Torr) at operating pressures < 10 ⁻⁴ mbar (< 0.75 x 10 ⁻⁴ Torr)	SV 200 + W 501 TRIVAC D 65 B + W 251	SV 300 + W 1001 DK 200 + W 251	SV 630 + W 2001 DK 200 + W 501	
Ordering Information	DIP 20 000	DIP 30 000	DIP 50 000	
Oil diffusion pump Standard EURO Standard Americas Special	Part No. 222 30 Part No. 500 882 Part No. 500 652	Part No. 222 35 Part No. 500 665 Part No. 500 653	Part No. 222 40 Part No. 500 728 Part No. 500 654	
Astrotorus baffle	Part No. 227 70	Part No. 227 75	Part No. 227 80	
Water flow monitor LR 20	Part No. 122 83	Part No. 122 83	Part No. 122 83	
Over-temperature protection switch	Part No. 122 84	Part No. 122 84	Part No. 122 84	
Contact thermometer	Part No. 218 81	Part No. 218 81	Part No. 218 81	
Resistance thermometer Pt 100 sensor	Part No. 200 02 958	Part No. 200 02 958	Part No. 200 02 958	
Pump fluid ⁵⁾	see "Pump Fluids for Diffusion Pumps" in section "General"			

¹⁾ Measured to DIN 28 427 with **DIFFELEN normal** as the pump fluid

²⁾ Measured to DIN 28 427 with **DIFFELEN normal** as the pump fluid. With pump fluids DC 705 and FPM gaskets the DIP pumps - when equipped with water-cooled baffles and after running a suitable degassing processes - are capable of attaining pressures below 1 x 10⁻⁸ mbar (0.75 x 10⁻⁸ Torr)

³⁾ The required quantity of cooling water refers to DT = 10 °C (50 °F). The discharge temperature should not exceed 30 °C (86 °F)

⁴⁾ Single- or two-stage rotary vane (TRIVAC; SV) or rotary piston vacuum pumps (E/DK) from our range of forevacuum pumps jointly with Roots vacuum pumps (RUVAC) in pump systems

⁵⁾ Oil must be purchased separately

Astrotorus Baffles

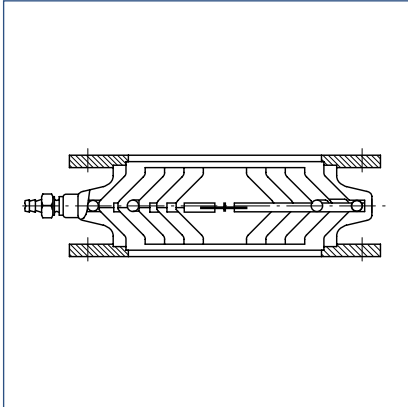

The cooling inserts of the astrotorus baffles are made of copper, whereas the housing and the connection flange are made of standard steel.

Section through an astrotorus baffle

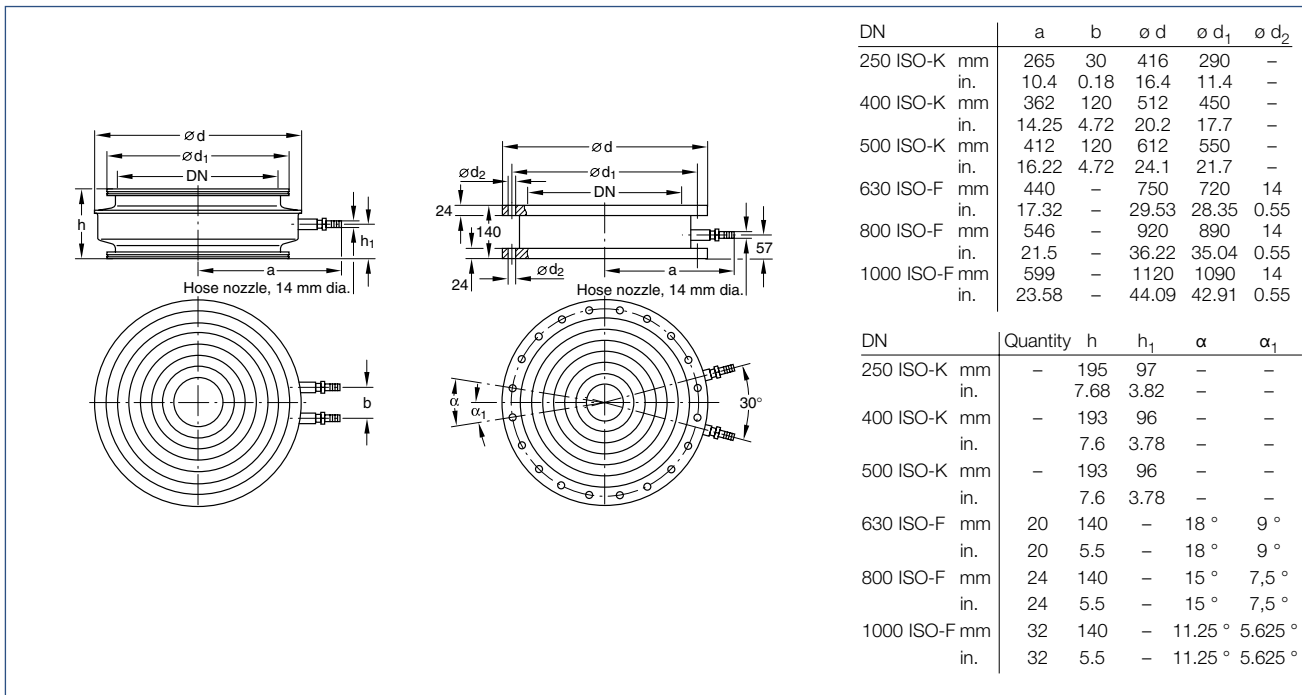

Dimensional drawing for the astrotorus baffle ISO-K (left) and ISO-F (right)

Technical Data		Astrotorus Baffles		
Connection to pump	DIP	3 000	8 000	12 000
HV connection flanges	DN	250 ISO-K	400 ISO-K	500 ISO-K
Throttling of the pumping speed, approx.	%	30	30	30
Conductance	$l \times s^{-1}$	3 000	9 000	12 000
Weight	kg (lbs)	25 (55.2)	30 (66.2)	65 (143.5)
Ordering Information		Astrotorus Baffles		
Astrotorus baffle		Part No. 227 50	-	-
0250 ISO-K		-	Part No. 227 60	-
0400 ISO-K		-	-	-
0500 ISO-K		-	-	Part No. 227 65

Technical Data		Astrotorus Baffles		
Connection to pump	DIP	20 000	30 000	50 000
HV connection flanges	DN	630 ISO-F	800 ISO-F	1000 ISO-F
Throttling of the pumping speed, approx.	%	30	30	30
Conductance	$l \times s^{-1}$	18 000	28 000	50 000
Weight	kg (lbs)	120 (264.9)	170 (375.3)	190 (419.4)
Ordering Information		Astrotorus Baffles		
Astrotorus baffle		Part No. 227 70	-	-
630 ISO-F		-	Part No. 227 75	-
800 ISO-F		-	-	-
1000 ISO-F		-	-	Part No. 227 80

Monitoring Instruments

Protection against Overheating

Water flow monitors are installed in the cooling water return section of the diffusion pump. When the cooling water throughput drops below a certain level, either the heater in the diffusion pump is switched off or a warning light or signal is triggered, depending of the type of circuit.

Type LR 10 for 60 to 600 l x h⁻¹
(3.78 to 37.8 gal/min)

Type LR 20 for 600 to 2400 l x h⁻¹
(37.8 to 151.2 gal/min)

The water throughput may be set within the limits stated with a high degree of reproducibility.

Water flow monitors may be installed in any orientation.

Max. switching capacity:
100 VA (230 V, 50/60 Hz).

Protection against Power Failure

A SECUVAC valve (see Product Section C14 "Vacuum Valves") must be installed in the forevacuum line in order to prevent damage to the diffusion pump or the pump fluid in the event of a power failure affecting backing pumps which are not equipped with an automatic isolation valve. Rotary vane vacuum pumps from the TRIVAC B Series are equipped with an automatic safety valve (intake isolation valve) as standard.

Protection against Pressure Increases in the Forevacuum Line

For protection against a pressure increase in the forevacuum line which is not caused by a power failure you may use our vacuum gauges which offer an adjustable switching threshold (see Product Section C16 "Total Pressure Gauges").

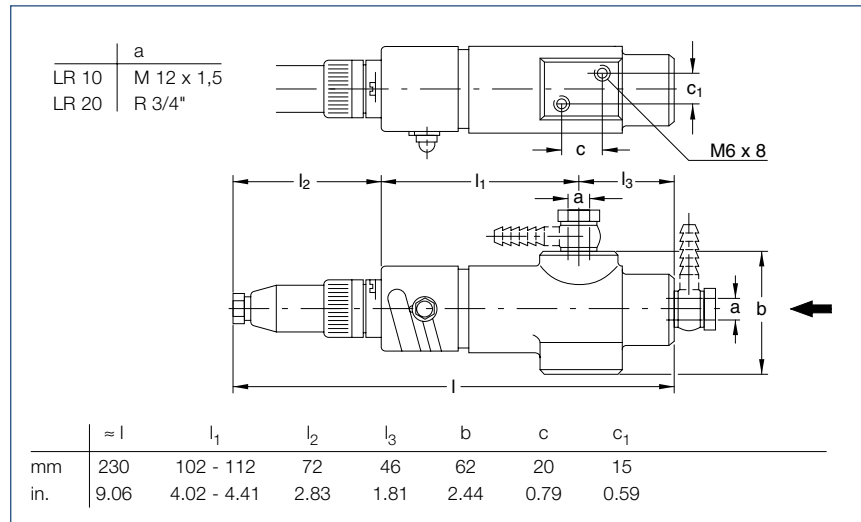

Dimensional drawing for the water flow monitors LR 10 and LR 20

* Only LR 10

Ordering Information	Water Flow Monitors
Water flow monitor LR 10 LR 20	Part No. 122 82 Part No. 122 83

Temperature dependant Switching Components for Automatic Pump System Control

The operational status of the diffusion pump depends on the temperature of the pump fluid in the pump boiler. Through temperature dependent switching components which are inserted into the pump boiler it is possible to monitor the operational status of the diffusion pump and signal its status to a process controller.

For this, the diffusion pump requires two thresholds. Depending on the type of pump, the upper threshold should be between 180 and 200 °C (356 and 392 °F) and the lower threshold between 90 and 100 °C (194 and 212 °F).

The upper threshold indicates that the diffusion pump is ready for operation and thus actuates certain devices, for example opening of the high vacuum valve ahead of the diffusion pump.

The lower threshold indicates that the diffusion pump has cooled down to such an extent that the backing pump and the cooling water supply may be switched off.

Over-temperature protection switches are used to monitor the temperature of the cooling water in the cooling water circuit of the diffusion pumps. When the temperature rises to unacceptably high levels (for example when the cooling water supply fails) the heater in the diffusion pump is switched off (correct electrical connection to the main supply is required). The use of over-temperature protection switches avoids unnecessary alarms that may be triggered by contaminated water when only a water flow monitor is used. The over-temperature protection switch is screwed on to a contact plate which is soldered to the cooling pipe on the pump's body.

Max. switching current: 5 A (230 V, 50/60 Hz)

Contact thermometer with a range from 0 to 400 °C (752 °F). Through a trailing pointer two switching thresholds may be set up independently. The current oil temperature and the thresholds which have been set up can be read off at the location of the diffusion pump. The contacting thermometer is not suited for remote signalling of temperatures.

Resistance thermometer Pt 100 sensor. The measurement range of this sensor depends on the temperature display unit used by the customer where also the required thresholds are set up. The Pt 100 sensor is ideal for remote signalling of temperatures.

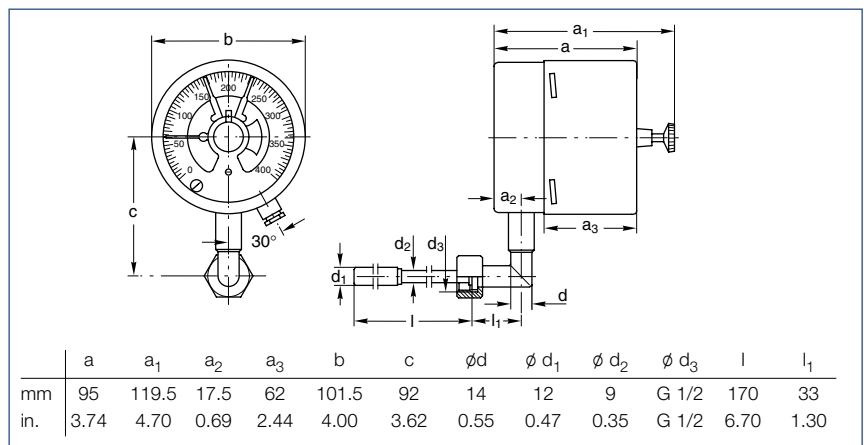

Dimensional drawing for the contact thermometer

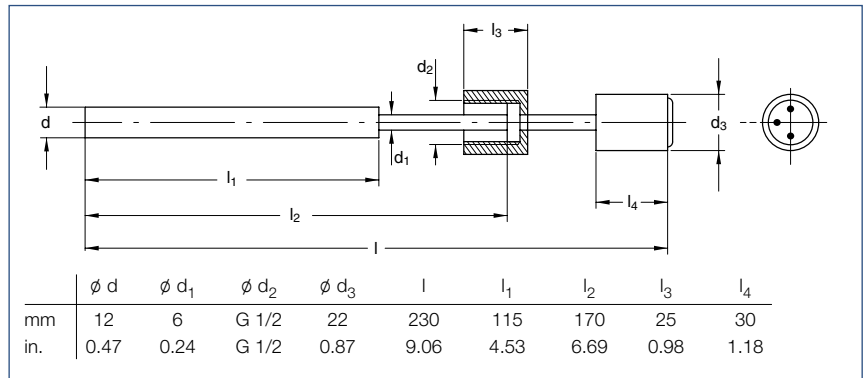

Dimensional drawing for the resistance thermometer Pt 100 sensor

Ordering Information	Monitoring Instruments
Over-temperature protection switch	Part No. 122 84
Contact thermometer (Measurement range 0 to 400 °C (32 to 752 °F), Rating at 220 V AC: 250 mA [resistive load], Weight: 1.7 kg (3.7 lbs))	Part No. 218 81
Resistance thermometer Pt 100 sensor	Part No. 200 02 958

Adsorption Traps with Aluminum Oxide Insert

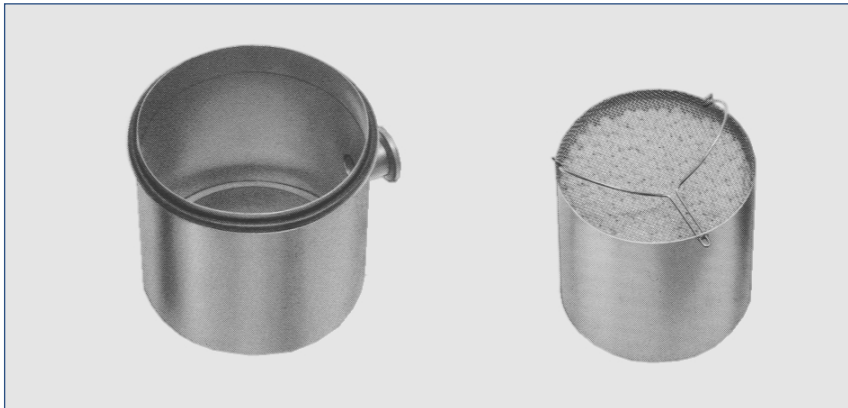

Adsorption trap (left) and inserts (right)

Adsorption traps are used in all those cases where a vacuum free of oil is to be produced with the aid of oil-sealed vacuum pumps.

Advantages to the User

- Backstreaming of oil is reduced by 99 %
- Long service life
- High conductance
- Filling can be easily exchanged
- Improvement in the ultimate pressure attained by backing pumps by one order of magnitude
- Stainless steel housing and insert
- NBR gasket

Typical Applications

- Product of an oil-free vacuum

Supplied Equipment

- Complete with insert
- Without adsorbent

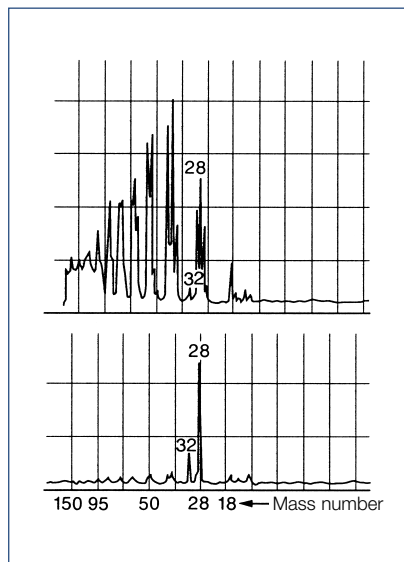

Residual gas spectrum; top ahead of a rotary vacuum pump, bottom ahead of a rotary vacuum pump with adsorption trap

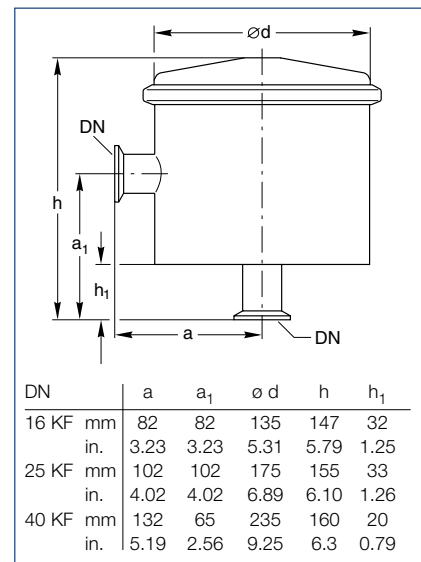

Dimensional drawing for the adsorption traps

Technical Data	Adsorption Traps		
	16 KF	25 KF	40 KF
Conductance at 10⁻² mbar (Torr) mbar x l x s ⁻¹ (Torr x l x sec)	4 (3.0)	6 (4.5)	12 (9.0)
Service live with Al oxide Months	3	3	3
Al oxide filling l (qts)	0.5 (0.53)	1.0 (1.06)	2.0 (2.1)
Weight, approx. kg (lbs)	1.3 (2.9)	1.3 (2.9)	4.0 (8.8)
Ordering Information	Adsorption Traps		
	16 KF	25 KF	40 KF
Adsorption trap	Part No. 854 14	Part No. 854 15	Part No. 854 16
Activated aluminum oxide, 2 l (approx. 1.5 l (approx. 1.1 kg (2.4 lbs))	Part No. 854 10	Part No. 854 10	Part No. 854 10

Sales and Service Net Worldwide

Germany

Leybold Vacuum GmbH
Bonner Strasse 498
D-50968 Cologne
Phone: +49-221-347 1234
Fax: +49-221-347 1245
sales@leybold.com

Leybold Vacuum GmbH
Sales Area North/East
Branch office Berlin
Buschkrugallee 33
1. Obergeschoss
D-12359 Berlin
Phone: +49-30-435 609 0
Fax: +49-30-435 609 10
sales.berlin@leybold.com

Leybold Vacuum GmbH
Sales Area South/Southwest
Branch office Munich
Karl-Hammerschmidt-Strasse 38
D-85609 Aschheim/Dornach
Phone: +49-89-357 33 90
Fax: +49-89-357 33 933
sales.muenchen@leybold.com
service.muenchen@leybold.com

Leybold Vacuum GmbH
Sales Area West
Branch office Cologne
Emil-Hoffmann-Straße 43
D-50996 Cologne-Suerth
Phone: +49-221-347 1270
Fax: +49-221-347 1291
sales.koeln@leybold.com

Leybold Vacuum GmbH
Service Center
Emil-Hoffmann-Straße 43
D-50996 Cologne-Suerth
Phone: +49-221-347 1439
Fax: +49-221-347 1945
service@leybold.com

Leybold Vacuum GmbH
Mobile after sales service
Emil-Hoffmann-Straße 43
D-50996 Cologne-Suerth
Phone: +49-221-347 1765
Fax: +49-221-347 1944
kundendienst@leybold.com

Leybold Vacuum
Dresden GmbH
Zur Wetterwarte 50, Haus 304
D-01109 Dresden
Service:
Phone: +49-351-88 55 00
Fax: +49-351-88 55 041
info@leybold-dresden.de
www.leybold-dresden.de

Europe

Belgium
Leybold Vacuum Nederland B.V.
Belgisch bijkantoor
Leuvensesteenweg 542-9A
B-1930 Zaventem
Sales:
Phone: +32-2-711 00 83
Fax: +32-2-720 83 38
sales.belgium@leybold.com
Service:
Phone: +32-2-711 00 82
Fax: +32-2-720 83 38
service.belgium@leybold.com

France
Leybold Vacuum France S.A.
7, Avenue du Québec
Z.A. de Courtaboeuf, B.P. 42
F-91942 Courtaboeuf Cedex
Sales and Service:
Phone: +33-1-69 82 48 00
Fax: +33-1-69 07 57 38
sales.france@leybold.com

Leybold Vacuum France S.A.
Valence Factory
640, Rue A. Bergès - B.P. 107
F-26501 Bourg-lès-Valence Cedex
Phone: +33-4-75 82 33 00
Fax: +33-4-75 82 92 69
marketing.valence@leybold.fr

Great Britain
Leybold Vacuum UK Ltd.
Waterside Way, Plough Lane
GB-London SW17 0HB
Sales:
Phone: +44-20-8971 7000
Fax: +44-20-8971 7001
sales@leybold.com
Service:
Phone: +44-20-8971 7030
Fax: +44-20-8971 7003
service@leybold.com

Italy
Leybold Vacuum Italia S.p.A.
8, Via Trasimeno
I-20128 Milano
Sales:
Phone: +39-02-27 22 31
Fax: +39-02-27 20 96 41
sales@leybold.it
Service:
Phone: +39-02-27 22 31
Fax: +39-02-27 20 96 41
service@leybold.it
Field Service Base
Z.I. Le Capanne
I-05021 Acquasparta (TR)
Phone: +39-0744-93 03 93
Fax: +39-0744-94 42 87
service@leybold.it

Netherlands
Leybold Vacuum Nederland B.V.
Computerweg 7
NL-3542 DP Utrecht
Sales and Service:
Phone: +31-346-58 39 99
Fax: +31-346-58 39 90
sales.netherlands@leybold.com
service.netherlands@leybold.com

Spain
Leybold Vacuum España S.A.
C/ Huelva, 7
E-08940 Cornellà de Llobregat
(Barcelona)
Sales:
Phone: +34-93-666 46 16
Fax: +34-93-666 43 70
sales.spain@leybold.com
Service:
Phone: +34-93-666 49 51
Fax: +34-93-685 40 10

Sweden
Leybold Vacuum Scandinavia AB
Box 9084
SE-40092 Göteborg
Sales and Service:
Phone: +46-31-68 84 70
Fax: +46-31-68 39 39
info@leybold.se
Visiting/delivery address:
Datavägen 57B
SE-43632 Askim

Switzerland
Leybold Vacuum Schweiz AG
Leutschenbachstrasse 55
CH-8050 Zürich
Sales:
Phone: +41-1-308 40 50
Fax: +41-1-302 43 73
sales@leybold.ch
Service:
Phone: +41-1-308 40 62
Fax: +41-1-308 40 60

America

USA
Leybold Vacuum USA Inc.
5700 Mellon Road
Export, PA 15632
info@leyboldvacuum.com
Sales:
Eastern & Central time zones
Phone: +1-724-327-5700
Fax: +1-724-733-1217
Pacific, Mountain,
Alaskan & Hawaiian time zones
Phone: +1-480-752-9191
Fax: +1-480-752-9494
Service:
Phone: +1-724-327-5700
Fax: +1-724-733-3799

Asia

P.R. China
Leybold Vacuum (Tianjin)
International Trade Co., Ltd.
Beichen Economic
Development Area (BEDA),
No. 8 Western Shuangchen Road
Tianjin 300400, China
Sales and Service:
Phone: +86-22-2697 0808
Fax: +86-22-2697 4061
leybold@leybold.com.cn

Leybold Vacuum (Tianjin)
Equipment Manufacturing Co., Ltd.
Beichen Economic
Development Area (BEDA),
No. 8 Western Shuangchen Road
Tianjin 300400, China
Phone: +86-22-2697 0808
Fax: +86-22-2697 4061
leybold@leybold.com.cn

Leybold Vacuum (Tianjin)
International Trade Co., Ltd.
Beijing Branch:
1-908, Beijing Landmark Towers
8 North Dongsanhuan Road
Chaoyang District
Beijing 100004, China
Sales and Service:
Phone: +86-10-6590-7607
Fax: +86-10-6590-7622

Leybold Vacuum (Tianjin)
International Trade Co., Ltd.
Shanghai Branch:
Add: No. 33, 76 Futedong San
Rd., Waigaoqiao FTZ,
Shanghai 200131, China
Sales and Service:
Phone: +86-21-5064-4666
Fax: +86-21-5064-4668
leybold_sh@leybold.com.cn

Leybold Vacuum (Tianjin)
Guangzhou Branch:
Add: G/F, #301 Building,
110 Dongguangzhuang Rd.
Tianhe District,
Guangzhou 510610, China
Sales:
Phone: +86-20-8723-7873
Phone: +86-20-8723-7597
Fax: +86-20-8723-7875
leybold_gz@leybold.com.cn

India
Leybold Vacuum India Pvt Ltd.
A-215 Road No. 30
MIDC Wagle Industrial Estate
Thane(W) - 400 604 Maharashtra
India
Sales and Service:
Phone: +91-22-2581 2929
Fax: +91-22-2581 2626
ivt2004@yahoo.com

Japan
Leybold Vacuum
Japan Co., Ltd.
Head Office
Tobu A.K. Bldg. 4th Floor
23-3, Shin-Yokohama
3-chome
Kohoku-ku, Yokohama-shi
Kanagawa-ken 222-0033
Sales:
Phone: +81-45-4713330
Fax: +81-45-4713323

Leybold Vacuum
Japan Co., Ltd.
Osaka Branch Office
MURATA Bldg. 7F
2-7-53, Nihl-Miyahara
Yodogawa-ku
Osaka-shi 532-0004
Sales:
Phone: +81-6-6393-5211
Fax: +81-6-6393-5215

Leybold Vacuum
Japan Co., Ltd.
Tsukuba Technical S.C.
Tsukuba Minami Daiichi
Kogyo Danchi
21, Kasumi-no-Sato,
Ami-machi, Inashiki-gun
Ibaraki-ken, 300-0315
Service:
Phone: +81-298-89-2841
Fax: +81-298-89-2838

Korea
Leybold Vacuum Korea Ltd.
#761-4, Yulkeum-ri,
SungHwan-eup, Cheonan-City
Choongchung-Namdo,
330-807, Korea
Sales:
Phone: +82-41-580-4420
Fax: +82-41-588-3737
Service:
Phone: +82-41-580-4415
Fax: +82-41-588-3737

Singapore
Leybold Vacuum
Singapore Pte Ltd.
No.1, International
Business Park,
B1-20B, The Synergy
Singapore 609917
Sales and Service:
Phone: +65-66652910
Fax: +65-65668202
vacuum@leyboldvac.com.sg

Taiwan
Leybold Vacuum Taiwan Ltd.
No 416-1, Sec. 3
Chung-Hsin Rd., Chu-Tung
Hsin-Chu, Taiwan, R.O.C.
Sales and Service:
Phone: +886-3-5833988
Fax: +886-3-5833999

Hotline

Sales: +49-221-347 1234

Service: +49-221-347 1765

sales@leybold.com
service@leybold.com

Leybold Vacuum GmbH
Bonner Strasse 498
D-50968 Cologne
Phone: +49-221 347-0
Fax: +49-221-347-1250
info@leybold.com

Leybold
vacuum

www.leybold.com